

Your Goals. Our Solutions.



Financial Reports



Budget



Company Structure

**TIME &  
ATTENDANCE  
MODULE**



الحل الأمثل والنظام الشامل لإدارة الأعمال  
The Total solution system for your business

A photograph of three business professionals in a modern office setting. A man in a suit and tie is on the left, smiling and looking towards the center. Two women in business attire are in the center and right, both smiling and looking at a large, dark-colored folder held by the woman in the center. The background features a large window with a grid pattern, suggesting a contemporary office environment.

Your Goals. Our Solutions.



Time & Attendance

**Optimum Time & Attendance Module** is an integrated system for all types of organizations to manage the attendance of staff online as well as for access control. The system is seamlessly connected to bio-metric devices for capturing attendance and access control. Unlimited shifts and periods can be defined in the system against which staff's attendance logs are compared to create reports for late coming, early out, breaks, absence and overtime. Staff can be assigned time groups in access control to restrict the entry during non-working hours.

**Optimum** provides powerful Security and Workflow. Specific system and operational roles can be defined at user or user group levels. A powerful document workflow ensures the smooth flow of documents within the organization. Any number of approval levels can be defined according to the nature of the document.



### Core Components:

1. Access Control Management.
2. Time & Attendance Management.
3. Time Sheet Management.
4. Roster Management.
5. Manpower Planning.
6. Setup.
7. Inquiries & Reports.



Company Structure



Budget



## Access Control

**Optimum Time & Attendance Module's** Access Control application contains following features:

- √ Connect & control the bio-metric attendance or access control devices.
- √ Manage users in the bio-metric devices.
- √ Registration of new users.
- √ Transfer data between devices.
- √ Log In & Out swipes of all users.
- √ Track users.
- √ Access Control & Tracking Reports.
- √ Control the opening & closing of doors.
- √ Connect devices to fire control systems.



Time & Attendance



Access Control

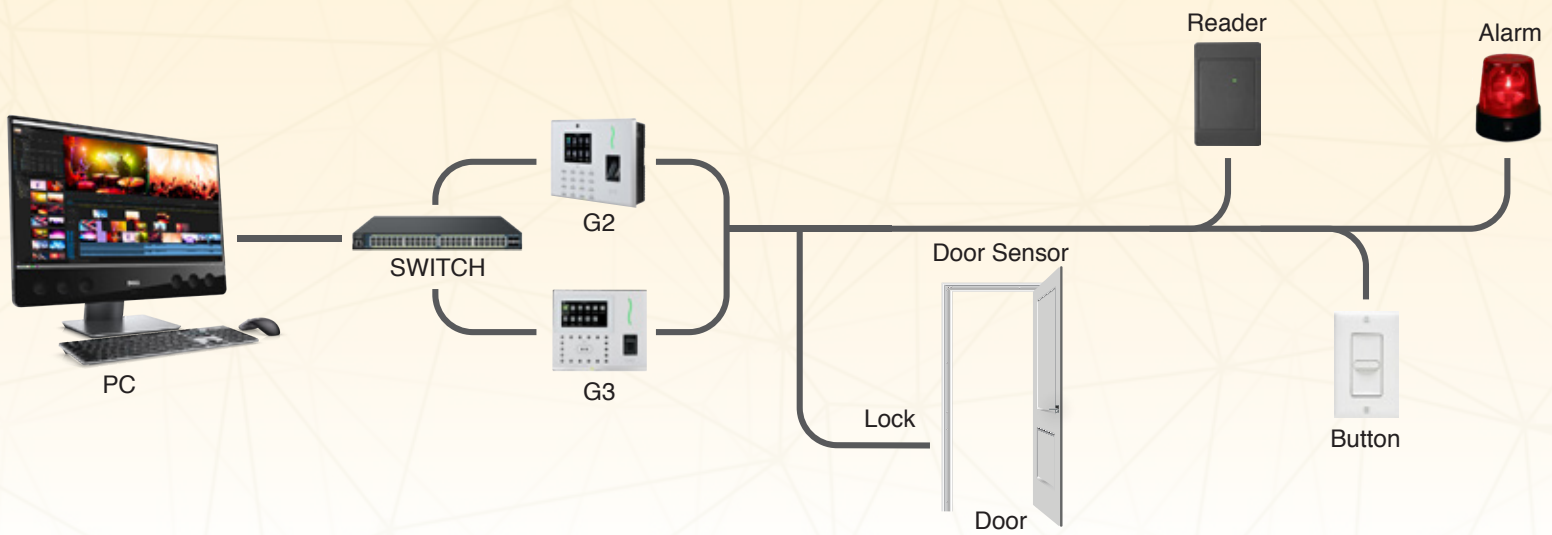

## Bio-Metric Readers

Some of the **Optimum** bio-metric readers available are:

### ✓ Optimum G3 Multi Bio-Metric Terminal with SilkID:



- Multiple Verifications: Face/Fingerprint/Card/Password.
- Revolutionary SilkID Fingerprint Sensor.
- Fingerprint Capacity 5,000.
- Face Capacity 3,000 (1:N) / 4,000 (1:1).
- Card Capacity 10,000.
- Transaction Capacity 100,000.
- Optional Functions: Wi-Fi / 3G, Battery (2,000 mAh).

### ✓ Optimum G2 Bio-Metric Terminal with SilkID:

- Multiple Verifications: Fingerprint / Card / Password.
- Revolutionary SilkID Fingerprint Sensor.
- Fingerprint Capacity 20,000 (Standard), 40,000 (Optional).
- Card Capacity 20,000.
- Transaction Capacity 200,000.
- Optional Functions: Wi-Fi / 3G.





### √ I-Clock v680 Multi Bio-Metric Terminal:



- Multiple Verification Fingerprint/Card/Password.
- Fingerprint Capacity 8,000.
- ID Card Capacity 10,000 (Optional).
- Record Capacity 200,000.
- Display 3.5-inch Screen.

### √ P160 Palm Recognition, Multi-Biometric T&A Terminal:

- Verification: Palm/Fingerprint/Card/Password.
- Fingerprint Capacity 3,000.
- Palm Capacity 600 (Standard).
- ID Card Capacity 10,000 (Optional).
- Display 2.8-inch TFT Color Display.
- Optional Functions: Wi-Fi / 3G / Battery Backup.





### √ ProCapture-X POE Fingerprint Access Control Terminal:



- Multiple Verifications: Fingerprint/Card/SE.
- Revolutionary SilkID Fingerprint Sensor.
- Fingerprint Capacity 20,000.
- Card Capacity 50,000.
- Transaction Capacity 500,000.
- Optional Functions: Wi-Fi.

### √ TF 1700 IP65 Rated Weather Proof Multi Bio-Metric Terminal:

- IP65 rated waterproof and dustproof structure.
- Authentication Finger/PIN/Card.
- Fingerprint Capacity 3,000, (8,000 Optional).
- Card Capacity 10,000 Cards.
- Log Capacity 50,000 Transactions.





Time & Attendance



Time & Attendance

## Time & Attendance

**Optimum Time & Attendance Module** manages employee attendance in the most efficient manner with following features:

√ Daily calculation for:

- Late In.
- Early Out.
- Absence.
- Overtime.
- Breaks (during working hours).

Attendance policy of any organization can be mapped to calculate the above.

√ Online self-service for users to do the following:

- Add a comment or submit excuse for any attendance exception.
- Attach related supporting documents.
- Submit the application electronically to get approval as per the defined workflow.

√ Manager's Decisions on employee exceptions in case of Late In, Early Out, Breaks or Absence with following options:





- Deduction from salary.
- Deduct annual leave.
- Deduct sick leave.
- No action.

√ Manager's Decisions on employee exceptions in case of Overtime with following options:

- Add payment to salary.
- Add to sick leave.
- Add to annual leave (Day in Lieu).
- No action.

√ Upload the attendance to payroll system for:

- Calculate employee salary.
- Addition or Deduction to leaves.
- Additions or Deductions to salary.

√ Inquiries & reports

√ Send requests & alerts electronically via e-mail.



Time & Attendance



Time & Attendance



## Time Sheet

**Optimum Time & Attendance Module** can also create and maintain project management time sheets as an option with following features:

- √ Create unlimited number of projects.
- √ Assign employees to multiple projects.
- √ Add working hours per employee by project.
- √ Calculate the cost by project.
- √ Calculate overtime.
- √ Upload or integrate attendance data to any payroll system.
- √ Inquiries & reports.
- √ Send reports & alerts electronically via e-mail.



Time & Attendance



Time Sheet



## Roster Management

**Optimum Time & Attendance Module** allows the users to create and maintain shifts and schedules/rosters for all employees with following features:

- √ Create & maintain all kinds of shifts.
- √ Generate rotation schedules for:
  - Users.
  - Management.
  - Branch.
  - Company.
- √ Rescheduling.
- √ Swap employee schedules.
- √ Online access to users to see their schedule/roster for a period
- √ Scheduling reports.
- √ Electronic alerts via e-mail.



Time & Attendance



Roster Management



Time & Attendance



Manpower Planning

## Manpower Planning

**Optimum Time & Attendance Module** can also include the project time planning as an option with following features:

- √ Create & maintain unlimited number of skills/trades.
- √ Personal file of the employee.
- √ Linking employees to skills.
- √ Employee distribution according to work plans for each project.
- √ Arrange for employees according to the plan & needs.
- √ Upload or integrate attendance data to any payroll system.
- √ Inquiries & reports.
- √ Send reports & alerts electronically via e-mail.



## Setup

**Optimum Time & Attendance Module** can be setup for the policies of any organization with following features:

- √ Calculation of attendance & overtime (normal/special) as per the policies of the organization.
- √ Create types of working days & holidays as per the requirement.
- √ Linking schedules to employees as per organization needs.
- √ Workflow setup for documentary movement of absence & overtime.



Time & Attendance



Setup



## Inquiries & Reports

**Optimum Time & Attendance Module** provides comprehensive inquiries and reports to manage and attendance of employees:

√ Detailed reports & inquiries about Late In/Early Out/Breaks in:

- Company.
- Branch.
- Department.
- Section.
- Unit.

√ Detailed reports & inquiries about Absence in:

- Company.
- Branch.
- Department.
- Section.
- Unit.

√ Detailed reports & inquiries about Project Planning with employment, skills, time & availability.



Time & Attendance



Inquiries & Reports



√ Detailed reports & inquiries about Overtime in:

- Company.
- Branch.
- Department.
- Section.
- Unit.

√ Detailed reports & queries for Project Time Sheets.



Time & Attendance



Inquiries & Reports

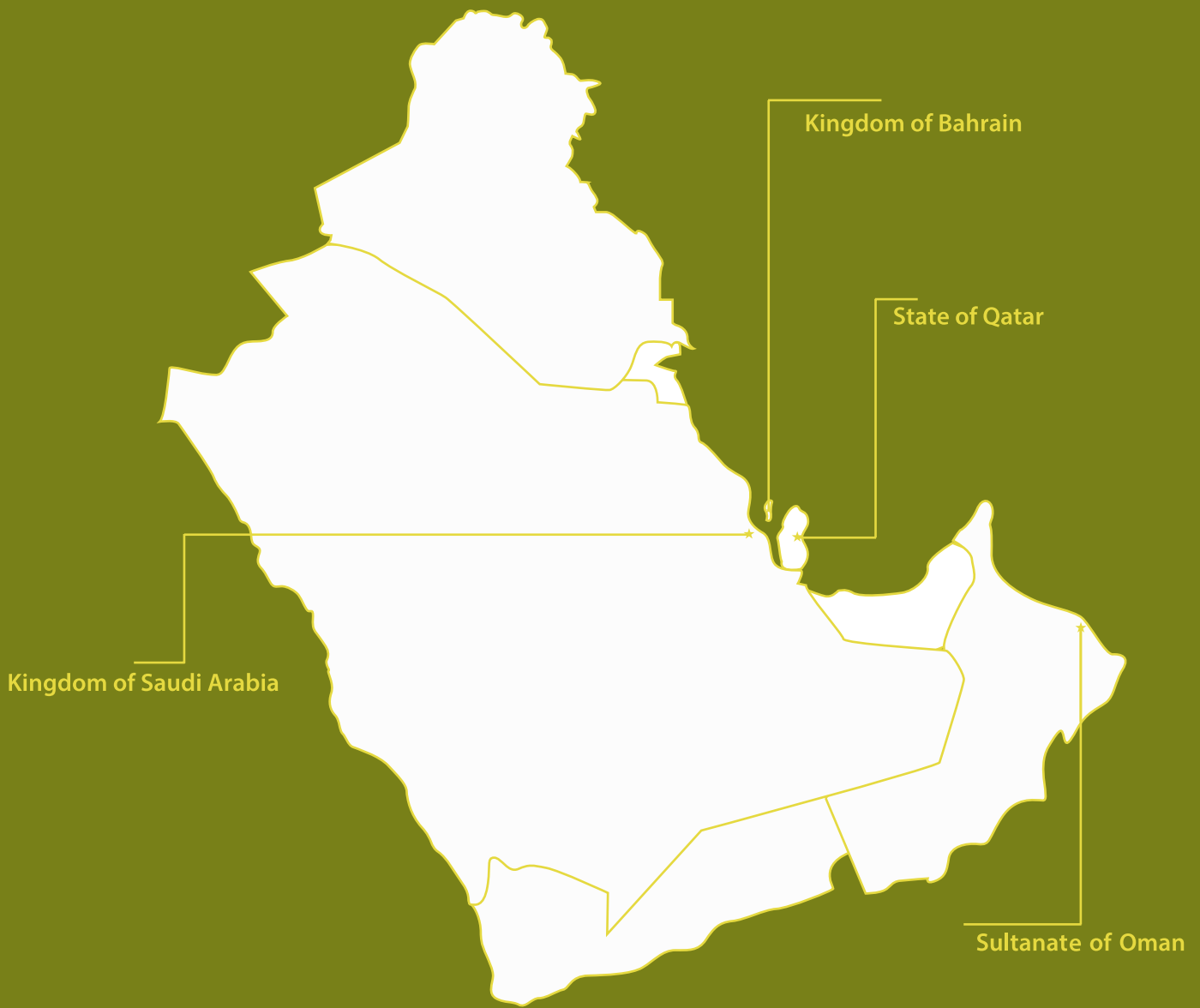

## Regional Offices

### Bahrain

P.O. Box 2949  
 Manama, Kingdom of Bahrain  
 Tel. +973 17 297227  
 Fax. +973 17 297 337

### Qatar

P.O. Box 31122  
 Doha, State Of Qatar  
 Tel. +974 4491 3232  
 Fax. +974 4491 3231

### Saudi Arabia

P.O. Box 3674  
 Al Khobar, Kingdom of Saudi Arabia  
 Tel. +966 3 889 0022  
 Fax. +966 3 889 8285

### Oman

P.O. Box 1801  
 Muscat, Sultanate of Oman  
 Te . + 968 2447 2223/4  
 Fax. +968 2448 1867

